

ULN2803A DARLINGTON TRANSISTOR ARRAY

SLRS049D – FEBRUARY 1997 – REVISED NOVEMBER 2005

- 500-mA Rated Collector Current (Single Output)
- High-Voltage Outputs . . . 50 V
- Output Clamp Diodes
- Inputs Compatible With Various Types of Logic
- Relay Driver Applications
- Compatible with ULN2800A Series

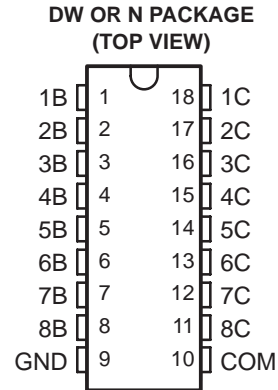

description/ordering information

The ULN2803A is a high-voltage, high-current Darlington transistor array. The device consists of eight npn Darlington pairs that feature high-voltage outputs with common-cathode clamp diodes for switching inductive loads. The collector-current rating of each Darlington pair is 500 mA. The Darlington pairs may be connected in parallel for higher current capability.

Applications include relay drivers, hammer drivers, lamp drivers, display drivers (LED and gas discharge), line drivers, and logic buffers. The ULN2803A has a 2.7-k Ω series base resistor for each Darlington pair for operation directly with TTL or 5-V CMOS devices.

ORDERING INFORMATION

TA	PACKAGE†		ORDERABLE PART NUMBER	TOP-SIDE MARKING
-40°C to 85°C	PDIP (N)	Tube of 20	ULN2803AN	ULN2803AN
	SOIC (DW)	Tube of 40	ULN2803ADW	ULN2803A
		Reel of 2000	ULN2803ADWR	

† Package drawings, standard packing quantities, thermal data, symbolization, and PCB design guidelines are available at www.ti.com/sc/package.



Please be aware that an important notice concerning availability, standard warranty, and use in critical applications of Texas Instruments semiconductor products and disclaimers thereto appears at the end of this data sheet.

PRODUCTION DATA information is current as of publication date. Products conform to specifications per the terms of Texas Instruments standard warranty. Production processing does not necessarily include testing of all parameters.

 **TEXAS
INSTRUMENTS**

POST OFFICE BOX 655303 • DALLAS, TEXAS 75265

Copyright © 2005, Texas Instruments Incorporated

ULN2803A DARLINGTON TRANSISTOR ARRAY

SLRS049D – FEBRUARY1997 – REVISED NOVEMBER 2005

logic diagram

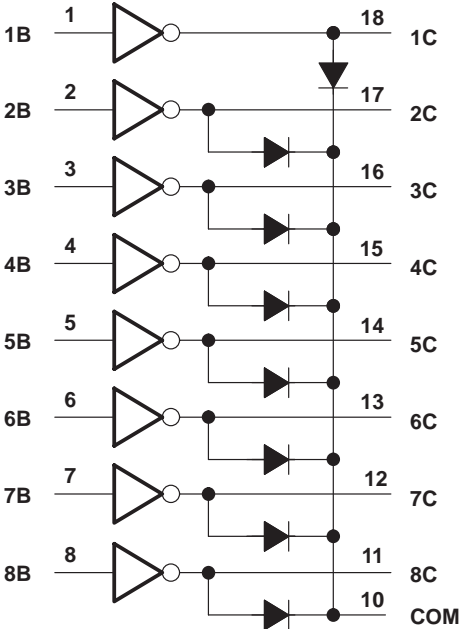

schematic (each Darlington pair)

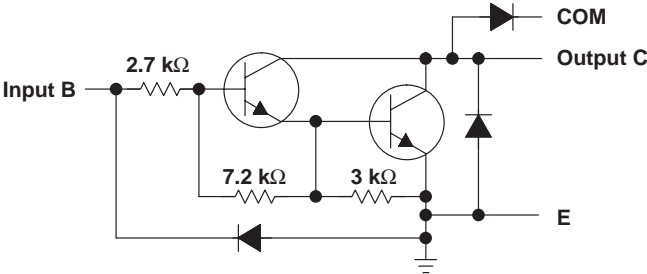

absolute maximum ratings at 25°C free-air temperature (unless otherwise noted)†

Collector-emitter voltage	50 V
Input voltage (see Note 1)	30 V
Continuous collector current	500 mA
Output clamp diode current	500 mA
Total substrate-terminal current	–2.5 A
Package thermal impedance, θ_{JA} (see Notes 2 and 3): DW package	TBD°C/W
N package	TBD°C/W
Operating virtual junction temperature, T_J	150°C
Storage temperature range, T_{stg}	–65°C to 150°C

† Stresses beyond those listed under “absolute maximum ratings” may cause permanent damage to the device. These are stress ratings only, and functional operation of the device at these or any other conditions beyond those indicated under “recommended operating conditions” is not implied. Exposure to absolute-maximum-rated conditions for extended periods may affect device reliability.

- NOTES: 1. All voltage values, unless otherwise noted, are with respect to the emitter/substrate terminal GND.
 2. Maximum power dissipation is a function of $T_J(\text{max})$, θ_{JA} , and T_A . The maximum allowable power dissipation at any allowable ambient temperature is $P_D = (T_J(\text{max}) - T_A)/\theta_{JA}$. Operating at the absolute maximum T_J of 150°C can affect reliability.
 3. The package thermal impedance is calculated in accordance with JESD 51-7.

electrical characteristics at 25°C free-air temperature (unless otherwise noted)

PARAMETER		TEST CONDITIONS	MIN	TYP	MAX	UNIT	
I_{CEX}	Collector cutoff current	$V_{CE} = 50\text{ V}$, $I_I = 0$, See Figure 1			50	μA	
$I_{I(\text{off})}$	Off-state input current	$V_{CE} = 50\text{ V}$, $T_A = 70^\circ\text{C}$, $I_C = 500\ \mu\text{A}$, See Figure 2	50	65		μA	
$I_{I(\text{on})}$	Input current	$V_I = 3.85\text{ V}$, See Figure 3		0.93	1.35	mA	
$V_{I(\text{on})}$	On-state input voltage	$V_{CE} = 2\text{ V}$, See Figure 4			2.4	V	
					2.7		
					3		
$V_{CE(\text{sat})}$	Collector-emitter saturation voltage	$I_I = 250\ \mu\text{A}$, See Figure 5		0.9	1.1	V	
			$I_C = 100\text{ mA}$,		1		1.3
			$I_C = 200\text{ mA}$, See Figure 5		1.3		1.6
I_R	Clamp diode reverse current	$V_R = 50\text{ V}$, See Figure 6			50	μA	
V_F	Clamp diode forward voltage	$I_F = 350\text{ mA}$, See Figure 7		1.7	2	V	
C_i	Input capacitance	$V_I = 0\text{ V}$, $f = 1\text{ MHz}$		15	25	pF	

switching characteristics at 25°C free-air temperature

PARAMETER		TEST CONDITIONS	MIN	TYP	MAX	UNIT
t_{PLH}	Propagation delay time, low- to high-level output	$V_S = 50\text{ V}$, $R_L = 163\ \Omega$, $C_L = 15\text{ pF}$, See Figure 8		130		ns
t_{PHL}	Propagation delay time, high- to low-level output			20		
V_{OH}	High-level output voltage after switching	$V_S = 50\text{ V}$, See Figure 9	$V_S - 20$			mV

ULN2803A DARLINGTON TRANSISTOR ARRAY

SLRS049D – FEBRUARY1997 – REVISED NOVEMBER 2005

PARAMETER MEASUREMENT INFORMATION

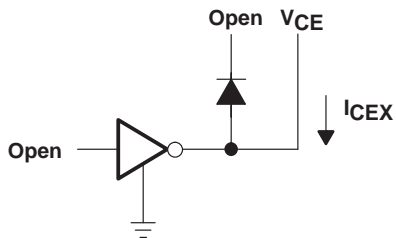

Figure 1. I_{CEX} Test Circuit

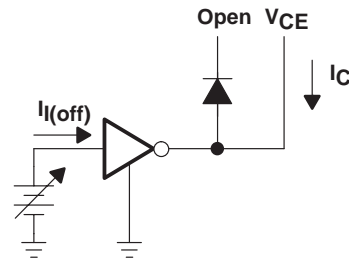

Figure 2. $I_{I(off)}$ Test Circuit

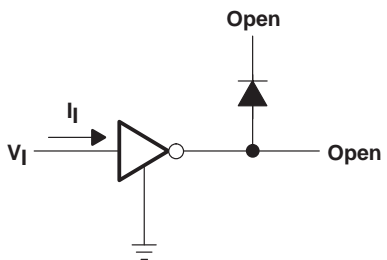

Figure 3. $I_{I(on)}$ Test Circuit

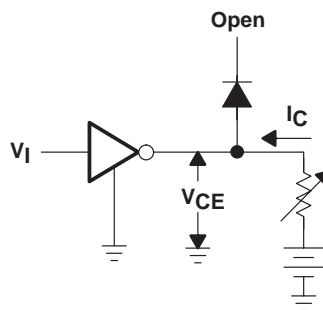

Figure 4. $V_{I(on)}$ Test Circuit

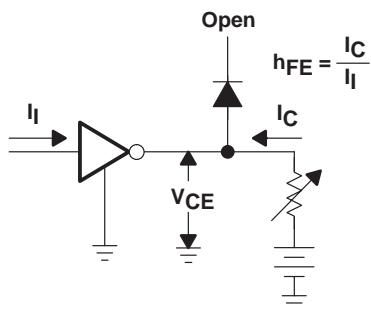

Figure 5. h_{FE} , $V_{CE(sat)}$ Test Circuit

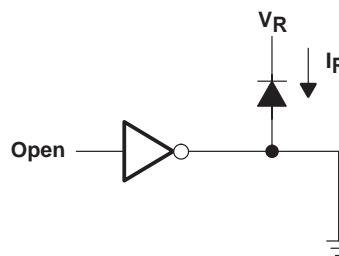

Figure 6. I_R Test Circuit

PARAMETER MEASUREMENT INFORMATION

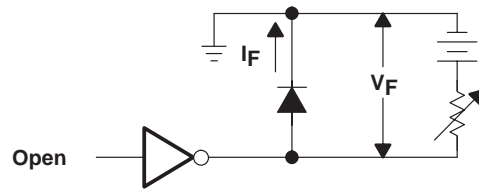
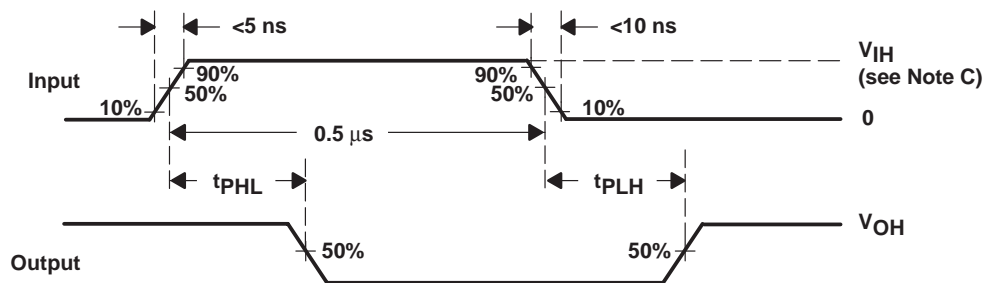
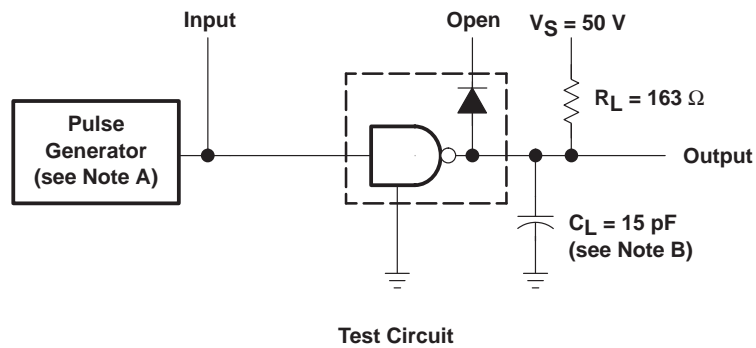

Figure 7. V_F Test Circuit



Voltage Waveforms

- NOTES: A. The pulse generator has the following characteristics: PRR = 1 MHz, $Z_O = 50\ \Omega$.
 B. C_L includes probe and jig capacitance.
 C. $V_{IH} = 3\text{ V}$

Figure 8. Propagation Delay Times

ULN2803A DARLINGTON TRANSISTOR ARRAY

SLRS049D – FEBRUARY1997 – REVISED NOVEMBER 2005

PARAMETER MEASUREMENT INFORMATION

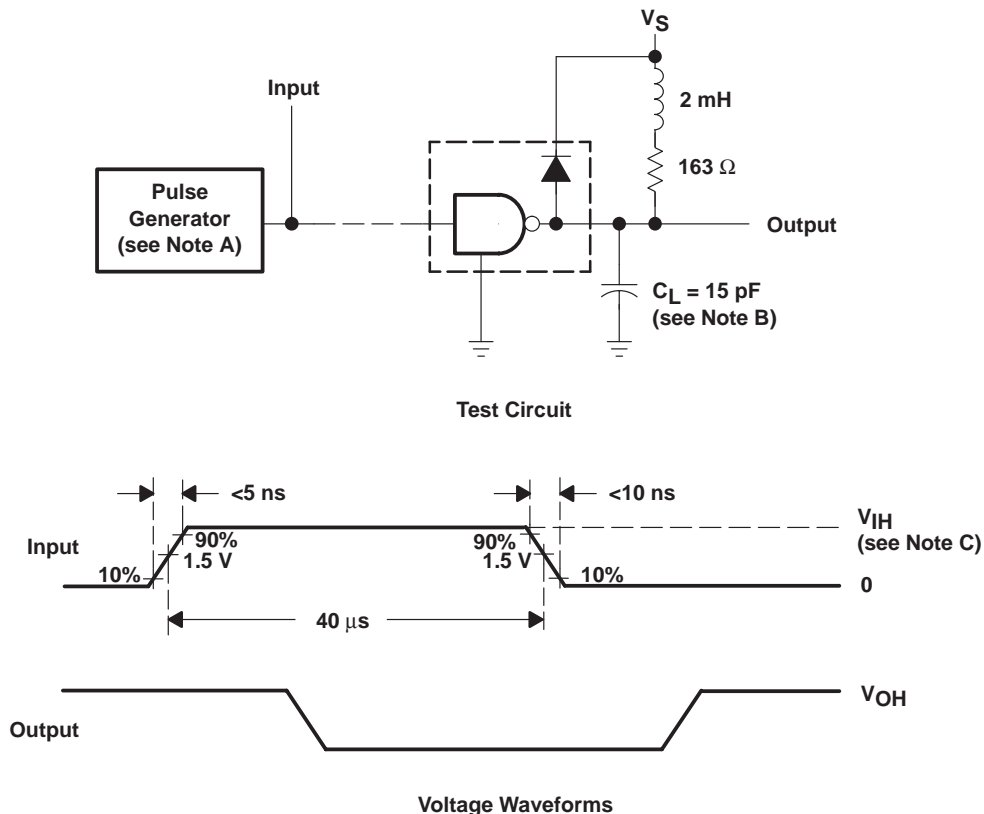

- NOTES: A. The pulse generator has the following characteristics: PRR = 12.5 KHz, $Z_O = 50 \Omega$.
 B. C_L includes probe and jig capacitance.
 C. $V_{IH} = 3$ V

Figure 9. Latch-Up Test

DW (R-PDSO-G18)

PLASTIC SMALL-OUTLINE PACKAGE

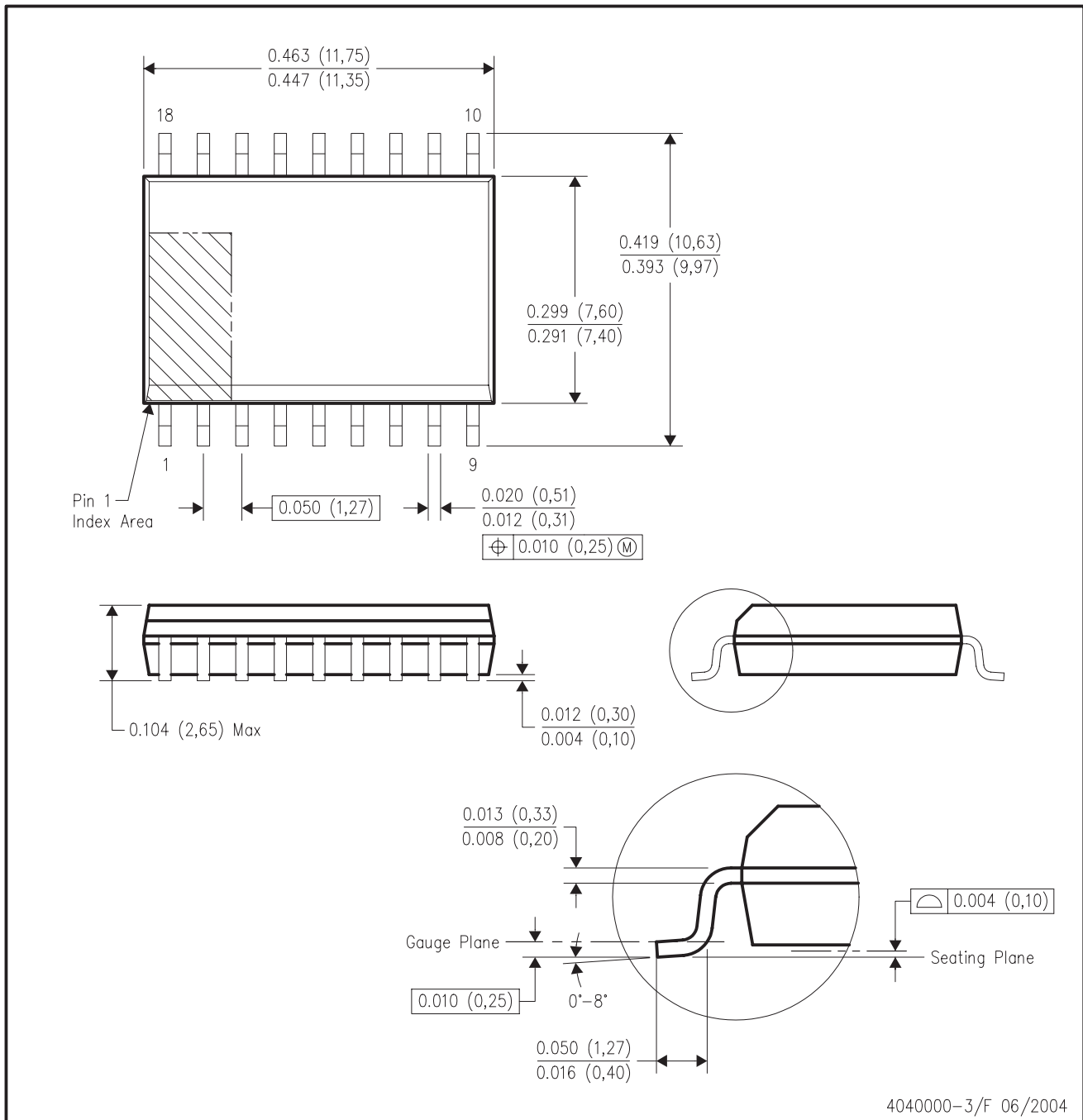

- NOTES:
- A. All linear dimensions are in inches (millimeters).
 - B. This drawing is subject to change without notice.
 - C. Body dimensions do not include mold flash or protrusion not to exceed 0.006 (0,15).
 - D. Falls within JEDEC MS-013 variation AB.

PACKAGING INFORMATION

Orderable Device	Status ⁽¹⁾	Package Type	Package Drawing	Pins	Package Qty	Eco Plan ⁽²⁾	Lead/Ball Finish	MSL Peak Temp ⁽³⁾
ULN2803ADW	ACTIVE	SOIC	DW	18	40	Green (RoHS & no Sb/Br)	CU NIPDAU	Level-2-260C-1YEAR
ULN2803ADWG4	ACTIVE	SOIC	DW	18	40	Green (RoHS & no Sb/Br)	CU NIPDAU	Level-2-260C-1YEAR
ULN2803ADWR	ACTIVE	SOIC	DW	18	2000	Green (RoHS & no Sb/Br)	CU NIPDAU	Level-2-260C-1YEAR
ULN2803ADWRG4	ACTIVE	SOIC	DW	18	2000	Green (RoHS & no Sb/Br)	CU NIPDAU	Level-2-260C-1YEAR
ULN2803AN	ACTIVE	PDIP	N	18	20	Pb-Free (RoHS)	CU NIPDAU	N / A for Pkg Type
ULN2803ANE4	ACTIVE	PDIP	N	18	20	Pb-Free (RoHS)	CU NIPDAU	N / A for Pkg Type

⁽¹⁾ The marketing status values are defined as follows:

ACTIVE: Product device recommended for new designs.

LIFEBUY: TI has announced that the device will be discontinued, and a lifetime-buy period is in effect.

NRND: Not recommended for new designs. Device is in production to support existing customers, but TI does not recommend using this part in a new design.

PREVIEW: Device has been announced but is not in production. Samples may or may not be available.

OBSOLETE: TI has discontinued the production of the device.

⁽²⁾ Eco Plan - The planned eco-friendly classification: Pb-Free (RoHS), Pb-Free (RoHS Exempt), or Green (RoHS & no Sb/Br) - please check <http://www.ti.com/productcontent> for the latest availability information and additional product content details.

TBD: The Pb-Free/Green conversion plan has not been defined.

Pb-Free (RoHS): TI's terms "Lead-Free" or "Pb-Free" mean semiconductor products that are compatible with the current RoHS requirements for all 6 substances, including the requirement that lead not exceed 0.1% by weight in homogeneous materials. Where designed to be soldered at high temperatures, TI Pb-Free products are suitable for use in specified lead-free processes.

Pb-Free (RoHS Exempt): This component has a RoHS exemption for either 1) lead-based flip-chip solder bumps used between the die and package, or 2) lead-based die adhesive used between the die and leadframe. The component is otherwise considered Pb-Free (RoHS compatible) as defined above.

Green (RoHS & no Sb/Br): TI defines "Green" to mean Pb-Free (RoHS compatible), and free of Bromine (Br) and Antimony (Sb) based flame retardants (Br or Sb do not exceed 0.1% by weight in homogeneous material)

⁽³⁾ MSL, Peak Temp. -- The Moisture Sensitivity Level rating according to the JEDEC industry standard classifications, and peak solder temperature.

Important Information and Disclaimer:The information provided on this page represents TI's knowledge and belief as of the date that it is provided. TI bases its knowledge and belief on information provided by third parties, and makes no representation or warranty as to the accuracy of such information. Efforts are underway to better integrate information from third parties. TI has taken and continues to take reasonable steps to provide representative and accurate information but may not have conducted destructive testing or chemical analysis on incoming materials and chemicals. TI and TI suppliers consider certain information to be proprietary, and thus CAS numbers and other limited information may not be available for release.

In no event shall TI's liability arising out of such information exceed the total purchase price of the TI part(s) at issue in this document sold by TI to Customer on an annual basis.

N (R-PDIP-T**)

PLASTIC DUAL-IN-LINE PACKAGE

16 PINS SHOWN

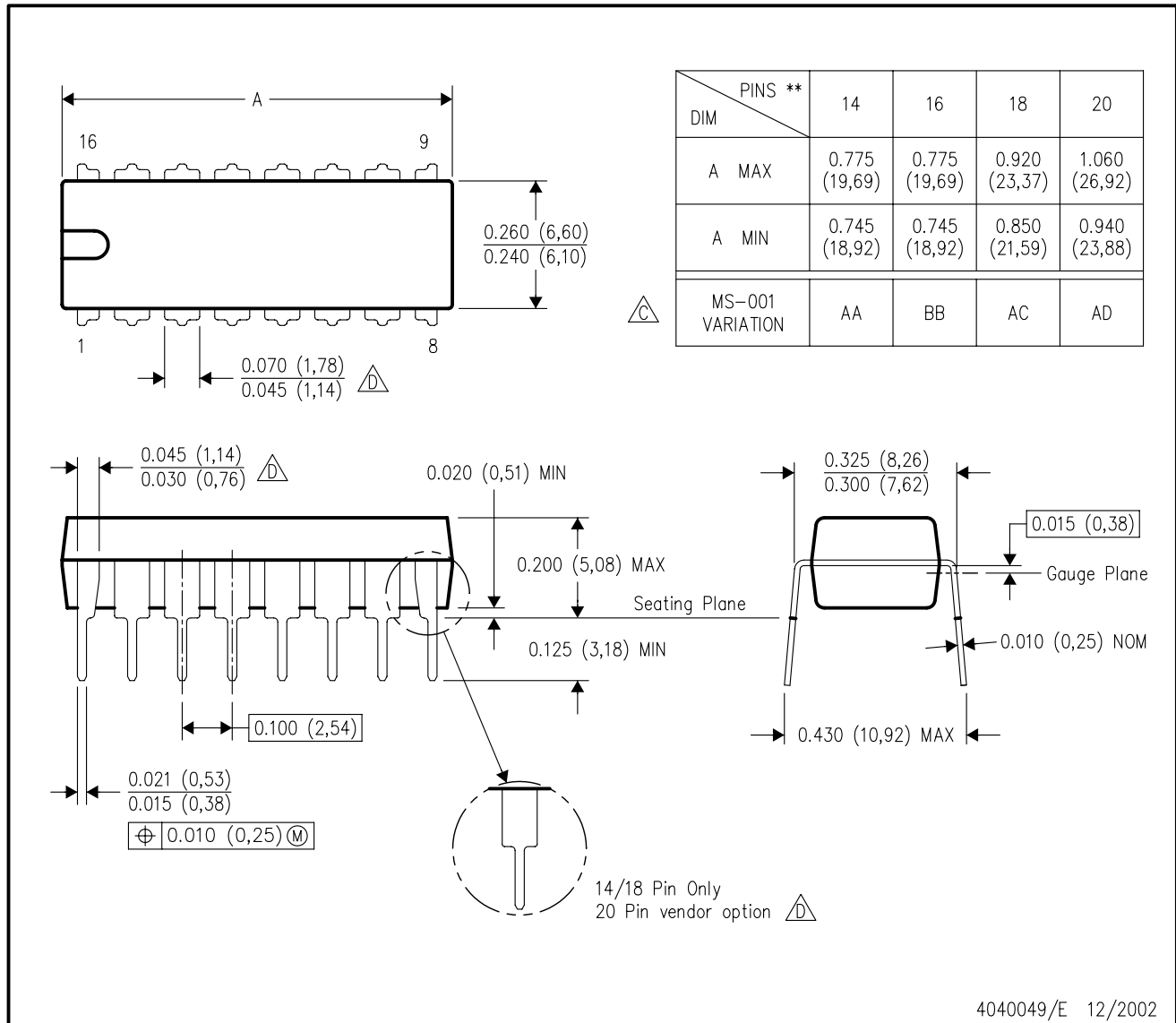

- NOTES:
- A. All linear dimensions are in inches (millimeters).
 - B. This drawing is subject to change without notice.
 - Falls within JEDEC MS-001, except 18 and 20 pin minimum body length (Dim A).
 - The 20 pin end lead shoulder width is a vendor option, either half or full width.

DW (R-PDSO-G18)

PLASTIC SMALL-OUTLINE PACKAGE

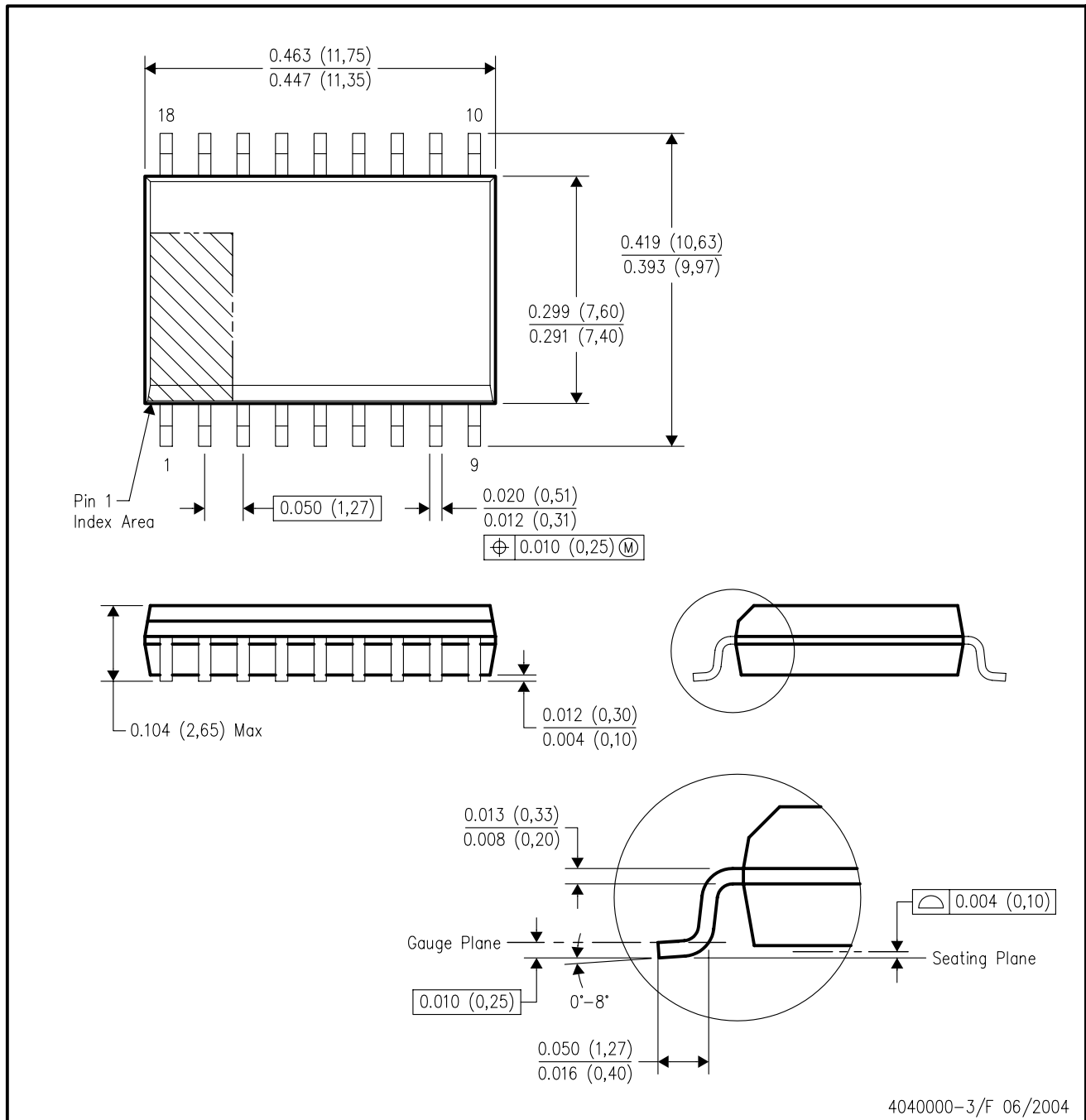

4040000-3/F 06/2004

- NOTES:
- A. All linear dimensions are in inches (millimeters).
 - B. This drawing is subject to change without notice.
 - C. Body dimensions do not include mold flash or protrusion not to exceed 0.006 (0,15).
 - D. Falls within JEDEC MS-013 variation AB.

IMPORTANT NOTICE

Texas Instruments Incorporated and its subsidiaries (TI) reserve the right to make corrections, modifications, enhancements, improvements, and other changes to its products and services at any time and to discontinue any product or service without notice. Customers should obtain the latest relevant information before placing orders and should verify that such information is current and complete. All products are sold subject to TI's terms and conditions of sale supplied at the time of order acknowledgment.

TI warrants performance of its hardware products to the specifications applicable at the time of sale in accordance with TI's standard warranty. Testing and other quality control techniques are used to the extent TI deems necessary to support this warranty. Except where mandated by government requirements, testing of all parameters of each product is not necessarily performed.

TI assumes no liability for applications assistance or customer product design. Customers are responsible for their products and applications using TI components. To minimize the risks associated with customer products and applications, customers should provide adequate design and operating safeguards.

TI does not warrant or represent that any license, either express or implied, is granted under any TI patent right, copyright, mask work right, or other TI intellectual property right relating to any combination, machine, or process in which TI products or services are used. Information published by TI regarding third-party products or services does not constitute a license from TI to use such products or services or a warranty or endorsement thereof. Use of such information may require a license from a third party under the patents or other intellectual property of the third party, or a license from TI under the patents or other intellectual property of TI.

Reproduction of information in TI data books or data sheets is permissible only if reproduction is without alteration and is accompanied by all associated warranties, conditions, limitations, and notices. Reproduction of this information with alteration is an unfair and deceptive business practice. TI is not responsible or liable for such altered documentation.

Resale of TI products or services with statements different from or beyond the parameters stated by TI for that product or service voids all express and any implied warranties for the associated TI product or service and is an unfair and deceptive business practice. TI is not responsible or liable for any such statements.

Following are URLs where you can obtain information on other Texas Instruments products and application solutions:

Products		Applications	
Amplifiers	amplifier.ti.com	Audio	www.ti.com/audio
Data Converters	dataconverter.ti.com	Automotive	www.ti.com/automotive
DSP	dsp.ti.com	Broadband	www.ti.com/broadband
Interface	interface.ti.com	Digital Control	www.ti.com/digitalcontrol
Logic	logic.ti.com	Military	www.ti.com/military
Power Mgmt	power.ti.com	Optical Networking	www.ti.com/opticalnetwork
Microcontrollers	microcontroller.ti.com	Security	www.ti.com/security
		Telephony	www.ti.com/telephony
		Video & Imaging	www.ti.com/video
		Wireless	www.ti.com/wireless

Mailing Address: Texas Instruments
Post Office Box 655303 Dallas, Texas 75265

Copyright © 2006, Texas Instruments Incorporated